

PRODUCT CATALOGUE 2025



Stoeger AIRGUNS



BERETTA
HOLDING

 BERETTA

 **Benelli**

FRANCHI

 **Stoeger**

 Uberti

sako

 *Burris*

STEINER 

 **TIKKA**

I&H

 **CHAPUIS ARMES**
FRANCE

 **Stoeger AIRGUNS**

Rottweil

norma
DEDICATED SINCE 1908

SWISS 

 **Geco**

 **MFS**
SINCE 1932

 **RWS**
SINCE 1886

Stoeger AIRGUNS
is the Brand launched in 2008
by the prestigious industrial **BERETTA HOLDING**

on the international airgun market,
a new niche for the company,
using synergy of Italian Engineering and Design,
Beretta Group experience in the hunting,
shooting and optic industries, production
plants and own Beretta distribution forces.
A team of italian designers and
engineers are permanently
developing new products.

Stoeger AIRGUNS
is the exclusive
BERETTA HOLDING
Brand in the field
of compressed
air shooting.



STOEGER AIRGUNS MISSION

Stoeger AIRGUNS mission is to offer innovative design, advanced ergonomics, fascinating models with excellent ballistic performance at the right price. Our vision is permanent innovation and development of new airgun lines motivating young people to approach the world of hunting and shooting in training by handling air guns and start to develop a proper shooting technique.

DESIGN AND PRODUCT DEVELOPMENT

Innovation in design is the brand's rooted pillar in our ability to understand consumer needs, tastes and aspirations. Italian designers and engineers are constantly engaged to create new possible models where stylistic innovation is combined with functionality. Determined proportions, clear contours, precise lines and pure surfaces are characteristics of Stoeger AIRGUNS design. Design is the focal point where vision, creative inspiration and technology converge. At every phase of the process, from design to industrialization, Stoeger AIRGUNS performs rigorously and tests the quality with precision.



INNOVATION AS A MUST

Stoeger AIRGUNS is synonymous with Innovation and Italian Design. The Airguns are exclusive, sensual, provocative and always unmistakably Italian. In fact, all our models are entirely idealized and designed in Italy. Stoeger AIRGUNS has always been the creator of dynamic and unrivalled rifles.

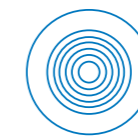

SPORTING HEART

Stoeger AIRGUNS rifles are recreational air rifles to have fun, to enjoy the first experience of hunting and shooting. Enjoy the nature, feel good and take up a different air rifle. Our rifles are incomparable through their blend of Fascinating Design and Supreme Shooting Ergonomics.



OUR PHILOSOPHY

Stoeger AIRGUNS has always in mind the design and implementation of something special that could convey new emotions to the shooters. The Stoeger AIRGUNS brand has a cutting-edge, distinct and streamlined design with multiple souls: Sporty, Elegant and Innovative.

DESIGNED IN ITALY



HUMAN TECH DESIGN

With its new Lines, Stoeger AIRGUNS creates the first compressed air rifles inspired by Urbino in Italy, a world heritage city, the cradle of Humanism. Stoeger AIRGUNS combines Urbino's technical inspiration with the innovative vision of Milan's designers whose experience in Industrial Design (ID) and User Experience (UX) is able to transform their technical inspirations into solid and attractive projects. Just thanks to this combination, Stoeger AIRGUNS creates a new method, based on 3 sound compact concepts: Functional Ergonomics, User Interaction Study, User Experience.



PRO ADAPTIVE CHECKERING

Stoeger AIRGUNS Pro Adaptive Checkering is the first technical result of our new "Human Tech Design" philosophy. It is the most versatile, efficient and progressive checkering developed so far, one of a kind. It is the result of a project which let shooters expose themselves to a new experience, become one with the airgun and find a perfect feeling with it. The special checkering progression actively and comfortably "fits" the gun, no matter the environment shooters find themselves in.



MULTI GRIP SYSTEM

Stoeger AIRGUNS offers a shooter the choice of the favourite grip and comfort thanks to the new Multi Grip System technology which, by means of an easy and intelligent system, let the rifle be customized. Finally, shooters can adapt the rifle to their own style. Stoeger AIRGUNS rifles are incomparable through their blend of: Fascinating Design, Supreme Shooting Ergonomics, Innovative Style, Technological Capability and Quality.



BEST ACCURACY

Stoeger AIRGUNS XM1 PCP rifles high precision and best accuracy: every Stoeger AIRGUNS XM1 PCP rifle is accuracy-tested to certify your rifle can perform the best accuracy in its category with a 5 shot group. Ammunition used: Stoeger AIRGUNS X-Sport / Stoeger AIRGUNS X-Match; Distance: 10 m; Power of the rifle: Full Power; N° of shots: 5.



XM1 SPORT ADVANCED ACCURACY

The Italian design of the SPORT muzzle brake allow the rifle to be more accurate on target by reducing the turbulence behind the pellets, in order to meet the competition shooter needs.



XM1 SPORT MATCH TRIGGER

The XM1 SPORT match trigger allows the shooter to find the best comfort trigger position in order to achieve the best target acquisition. The length of pull (max. range of 20 mm), inclination and rotation are all fully adjustable. Thanks to the numerous adjustments, the whole trigger action is fluid, soft, light and instantaneous.



FREE FLOATING BARREL

The Free-Floating Barrel system represents a cutting-edge design in the world of air-shooting, particularly in precision shooting. This system redefines how an Airguns barrel is positioned and supported within the Airguns frame. The Free-Floating Barrel system allows the barrel to "float" independently within the Airguns frame. This means that the barrel is not in direct contact with the stock or frame. This innovative technical design has a profound impact on accuracy. This enhanced stability and consistency are fundamental to achieving pinpoint accuracy in air-shooting, where even slight variations in the barrel's position or vibration can make a significant difference in where the shot lands.

*S3 Suppressor Patented: EP3023729, US10514224, ZL201580063122.8
 **S4 Suppressor Patented: EP3023729, US10514224, ZL201580063122.8



ADJUSTABLE TRIGGER

The adjustable trigger feature is designed to provide shooters with the ability to customize their shooting experience to achieve the highest levels of accuracy and comfort. This feature allows the shooter to finely adjust the trigger's pull weight, offering a range from 600 grams to 350 grams. By being able to modify the trigger's pull weight, shooters can find the perfect balance that suits their individual preferences. In essence, this adjustable trigger system empowers shooters to fine-tune their rifle's trigger to match their specific shooting style and requirements, whether that's optimized precision or a more relaxed and comfortable shooting experience.



ADJUSTABLE HAMMER SPRING

The hammer spring adjustment empowers shooters to fine-tune the hammer's opening, enabling precise control over the rifle's power output based on the type and shape of pellets used. Another important technological plus that makes Stoeger AIRGUNS rifles increasingly precise, reliable and versatile in every type of use, in hunting small and medium game, in precision sports shooting and in long-distance performance.



S3 SUPPRESSOR PATENTED*

Completely developed from scratch, it is the first suppressor in the world to have an interchangeable front sight and an air decompression chamber that further enhances the performance of the air regulation baffles, optimized to be more performing than the S2 version. The revolutionary design of the S3 Suppressor has made it possible to develop a longer barrel (35 mm), hence with a greater precision of shooting.



S4 SUPPRESSOR PATENTED**

The latest Stoeger AIRGUNS design evolution of the integral silencer system. It combines the Dual-Effect of the baffles and decompression chamber and now the additional compensator technology. The most advanced technology to reduce the noise better than ever. The best in its class.



RX LINE

The RX Line has been developed having in mind a new challenge: the design and implementation of something special that could convey new emotions to both the enthusiastic shooters and those who just want to have fun in the open air or at the shooting range. The RX Line represents the perfect match between technological style, technical efficiency and care for details. The elegant and ergonomic shapes makes the gun fit perfectly to the shooter. Stoeger AIRGUNS and its RX Line translate technology in style.



XM1 LINE

The PCP XM1 Line ensures the best performance in every shooting situation, thanks to the ergo/anatomical studies performed by Italian Engineers (Human Tech Design) and the best weight-stability ratio of the rifle. XM1 has a cutting-edge, distinct and streamlined design with multiple souls: sporty, elegant and innovative. A distinct style of Stoeger AIRGUNS coupled with traits of a sports rifle and hunting rifle. XM1 provides to the shooter a uniquely emotional experience. With its strong personality, pure design and absolute sportiness, PCP XM1 Line is one of a kind.



XRD LINE

The first handgun powered by a CO2 technology branded Stoeger Airguns. Introducing the all-new powered by CO2 technology with 12-gram cartridges, the XRD50 is easy to use and incredibly fun. Designed specifically for training engagements, shooting practice, and domestic self-defense, the XRD50 showcases Stoeger Airguns' dedication to innovation.

XRD50



**TRAINING
AND FUN**

 **Stoeger** AIRGUNS

 **BERETTA**
HOLDING

12,7 mm/.50: 100 m/s - 330 fps | 131 m/s - 430 fps

XRD50

Introducing the all-new Powered by CO2 technology with 12-gram cartridges, the XRD50 is easy to use and incredibly fun. Designed specifically for training engagements, shooting practice and domestic use, the XRD50 showcases Stoeger Airguns' dedication to innovation.



AMMUNITION MAGS

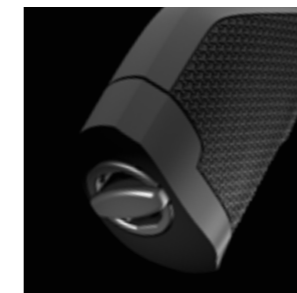

CO2 CHAMBER CAP

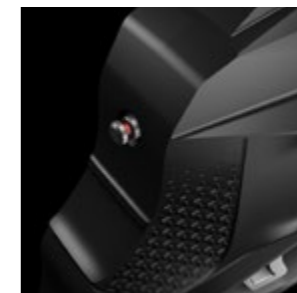

PRESSURE INDICATOR PIN (PIP)



MUZZLE BRAKE

XRD50 - TECHNICAL FEATURES

Power Source CO2	< 7,5 J	< 12,7 J
Caliber	12,7 mm/.50	12,7 mm/.50
Height	176mm	176mm
Length	307mm	307mm
Width	41mm	41mm
Weight	700g ca.	700g ca.
Barrel	138mm	138mm
Max Pressure	6Mpa	6Mpa
Velocity	330FPS	430FPS

XM1 PCP LINE



XM1 Ranger



XM1 Ranger Carbon



XM1 Scout



XM1 Scout Carbon



XM1 Bullpup



XM1 Bullpup Carbon



XM1



XM1 Sport



XM1 Sport Suppressor



XM1 Suppressor



 **Stoeger** AIRGUNS

 **BERETTA**
HOLDING

XM1 RANGER

XM1 SCOUT



**THE FEARLESS
RIFLES**

 **Stoeger** AIRGUNS

 **BERETTA**
HOLDING

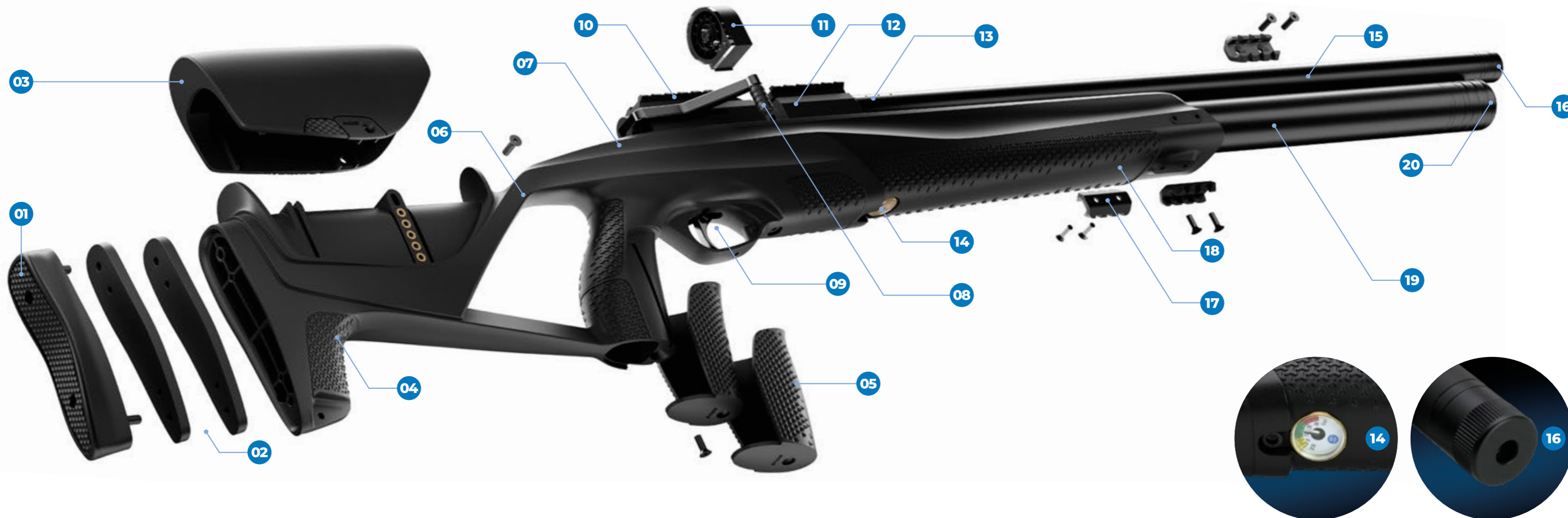

01 Comfort rear pad
To provide the best comfort and stability to the shooter

02 Two spacers to adapt the LOP
To the shooter needs, LOP 355 mm max. (med.= 349 mm, min.= 343 mm)

03 Adjustable comb
5 different position (from 0 to +30 mm) to find your best comfort and adapt the rifle to any kind of scopes and shooters

04 Improved ergonomics
The advanced stock design provide multiple grip and shooting position

05 Interchangeable pistol grip
Two different size of pistol grip to provide the best comfort and ergonomics to the shooters

06 Ultimate Thumbhole stock design
For a perfect ergonomics and comfort

07 Adjustable hammer spring
To provide the best power regulation according with the type of pellets used

08 Straight-pull loading system
To provide smooth and fast reload

09 Adjustable trigger pull
From 700 g to 400 g to achieve the maximum accuracy on target and the best comfort

10 Integrated picatinny rail
To provide solid and accurate scope mount

11 Hi-Capacity Magazine
12 rounds in 4,5 mm; 10 rounds in 5,5 mm; 9 rounds in 6,35 mm

12 Aluminum receiver
Lightweight and robust, with strong black matte anodized finishing

13 Decompression chamber and holes
To minimize the air turbulence at the muzzle

14 Air regulator gauge
To check the exact moment to refill the air tank

15 Barrel lengths: XM1 Ranger 600 mm, XM1 Scout 450 mm
Free floating and extra long barrel to provide maximum power and accuracy

16 Threaded muzzle
½" UNF thread to fit various muzzle devices

17 Three picatinny rails
To give at the user the possibility to fit any kind of bipods and accessories

18 Flat style varmint forend
To provide max stability on bench rest

19 Air tank
XM1 Ranger 300 cc - 250 bar
XM1 Scout 200 cc - 250 bar
High air capacity to provide a longer shooting of session before refill

20 Air tank gauge
To accurate check the air tank pressure

4,5 mm/.177: 310 m/s - 1020 fps 5,5 mm/.22: 270 m/s - 890 fps 6,35 mm/.25: 265 m/s - 870 fps

XM1 RANGER

The constant quest for improvement has led Stoeger AIRGUNS to develop two new rifles, the XM1 RANGER and the XM1 SCOUT, expanding the range of the XM1 line, offering ideal solutions for small and medium game hunting, as well as long-range and precision shooting.



INCLUDED WITH THE RIFLE



PRO ADAPTIVE LENGTH
Length of pull adjustable with spacers for optimal comfort



ADJUSTABLE COMB
5 different position (from 0 to +30 mm) to find the best comfort and adapt the rifle to any kind of scopes and shooters

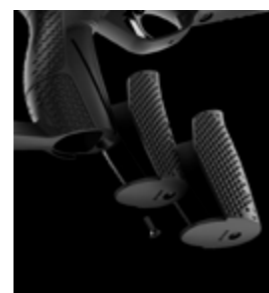

INTERCHANGEABLE PISTOL GRIP
Two different size of pistol grip to provide the best comfort and ergonomics to the shooters



STRAIGHT-PULL LOADING SYSTEM
To provide smooth and fast reload



THREE PICATINNY RAILS
To give at the user the possibility to fit any kind of bipods and accessories



ADJUSTABLE HAMMER SPRING
To provide the best power regulation according with the type of pellets used



ADJUSTABLE TRIGGER
From 700 g to 400 g to achieve the maximum accuracy on target and the best comfort

XM1 RANGER - TECHNICAL FEATURES

Caliber	4,5 mm /.177 - 5,5 mm /.22 - 6,35 mm /.25	Weight (+/- 0,1)	3,55 Kg
Power source	Precharged pneumatic (PCP) with integrated regulator	Velocity cal. 4,5 mm (+/- 2%) 0,69 g pellet	Up to 310 m/s - 1020 fps
Cocking system	Straight Pull	Velocity cal. 5,5 mm (+/- 2%) 1,37 g pellet	Up to 270 m/s - 890 fps
Trigger System	Two stage trigger - Three lever Adjustable from 0,7 to 0,4 Kg (factory preset 0,7 Kg)	Velocity cal. 6,35 mm (+/- 2%) 2 g pellet	Up to 265 m/s - 870 fps
Safety	Manual on trigger	Max energy delivered (+/- 2%)	Cal. 4,5 mm / .177: 33J - Cal. 5,5 mm / .22: 50J - Cal. 6,35 mm / .25: 70J
Sight / Scope Rail	No sight - Picatinny rail machined on the receiver	Cylinder Pressure	250 BAR / 3630 PSI fill pressure / Integrated pressure gauge + Integrated pressure gauge for air regulator check
Stock	Human Tech Design Synt. Stock - Ergonomic Features - MGS Technology Ambidextrous Stock Design - Adjustable 5 positions comb	Cylinder Size	300cc
Finish	Black Synthetic stock - Black anodized receiver and air cylinder	Rotary magazine	12 shots magazine in cal. 4,5 mm /.177 - 10 shots magazine in cal. 5,5 mm /.22 9 shots magazine in cal. 6,35 mm /.25
Total length	1097 mm / 43.2"	Included in the box	Charging connector, 2 magazines, 3 side rails, MGS kit, instruction manual, spare O-rings
Barrel	600 mm - Free floating - Rifled, blued steel barrel with black anodized barrel cover and integrated air decompression chamber - Twist rate (mm) 1:480 - Muzzle thread 1/2" UNF	Suggested for	Medium game hunting / Small game hunting / Varmint control / Target shooting



THE STOEGER AIRGUNS XM1 SCOUT HAS BEEN AWARDED BY THE PRESTIGIOUS GUNS & AMMO AS AIR GUN OF THE YEAR 2024

This year's innovation was the introduction of the air gun category, in which the PCP XM1 SCOUT rifle fully met the requirements set by the Outdoor Sportsman Group (OSG) in Grand Junction, Colorado. Only the most innovative and cutting-edge products available in 2024 were selected and evaluated by the Guns & Ammo staff to determine the best product of the year. The voting concluded with the awarding of the AIR GUN OF THE YEAR award to the XM1 SCOUT model from Stoeger AIRGUNS.

The rifle was awarded in terms of excellence: build quality, material quality, and technological innovation. All factors that contribute to ballistic performance at a very high level. The unmistakable know-how of Stoeger AIRGUNS in the field of air rifles is combined with a constant process of design and research, generating innovative solutions while also paying attention to style and design, completely made in Italy.



4,5 mm/.177: 295 m/s - 965 fps 5,5 mm/.22: 255 m/s - 840 fps 6,35 mm/.25: 245 m/s - 805 fps

XM1 SCOUT

The constant quest for improvement has led Stoeger AIRGUNS to develop two new rifles, the XM1 RANGER and the XM1 SCOUT, expanding the range of the XM1 line, offering ideal solutions for small and medium game hunting, as well as long-range and precision shooting.



INCLUDED WITH THE RIFLE



PRO ADAPTIVE LENGTH
Length of pull adjustable with spacers for optimal comfort



ADJUSTABLE COMB
5 different position (from 0 to +30 mm) to find the best comfort and adapt the rifle to any kind of scopes and shooters

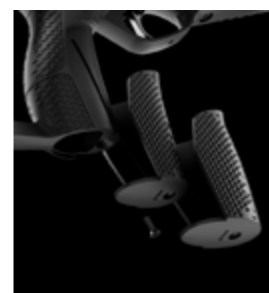

INTERCHANGEABLE PISTOL GRIP
Two different size of pistol grip to provide the best comfort and ergonomics to the shooters



STRAIGHT-PULL LOADING SYSTEM
To provide smooth and fast reload

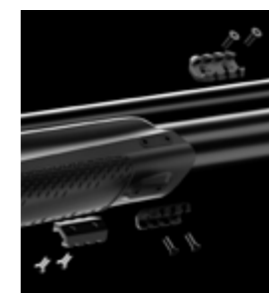

THREE PICATINNY RAILS
To give at the user the possibility to fit any kind of bipods and accessories



ADJUSTABLE HAMMER SPRING
To provide the best power regulation according with the type of pellets used



ADJUSTABLE TRIGGER
From 700 g to 400 g to achieve the maximum accuracy on target and the best comfort

XM1 SCOUT - TECHNICAL FEATURES

Caliber	4,5 mm /.177 - 5,5 mm /.22 - 6,35 mm /.25	Weight (+/- 0,1)	3,3 Kg
Power source	Precharged pneumatic (PCP) with integrated regulator	Velocity cal. 4,5 mm (+/- 2%) 0,69 g pellet	Up to 295 m/s - 965 fps
Cocking system	Straight Pull	Velocity cal. 5,5 mm (+/- 2%) 1,37 g pellet	Up to 255 m/s - 840 fps
Trigger System	Two stage trigger - Three lever Adjustable from 0,7 to 0,4 Kg (factory preset 0,7 Kg)	Velocity cal. 6,35 mm (+/- 2%) 2 g pellet	Up to 245 m/s - 805 fps
Safety	Manual on trigger	Max energy delivered (+/- 2%)	Cal. 4,5 mm /.177: 30J - Cal. 5,5 mm /.22: 44J - Cal. 6,35 mm /.25: 60J
Sight / Scope Rail	No sight - Picatinny rail machined on the receiver	Cylinder Pressure	250 BAR / 3630 PSI fill pressure / Integrated pressure gauge + Integrated pressure gauge for air regulator check
Stock	Human Tech Design Synt. Stock - Ergonomic Features - MGS Technology Ambidextrous Stock Design - Adjustable 5 positions comb	Cylinder Size	200cc
Finish	Black Synthetic stock - Black anodized receiver and air cylinder	Rotary magazine	12 shots magazine in cal. 4,5 mm /.177 - 10 shots magazine in cal. 5,5 mm /.22 9 shots magazine in cal. 6,35 mm /.25
Total length	957 mm / 37.7"	Included in the box	Charging connector, 2 magazines, 3 side rails, MGS kit, instruction manual, spare O-rings
Barrel	460 mm - Free floating - Rifled, blued steel barrel with black anodized barrel cover and integrated air decompression chamber - Twist rate (mm) 1:480 - Muzzle thread 1/2" UNF	Suggested for	Medium game hunting / Small game hunting / Varmint control / Target shooting



- 01 Interchangeable cheekpiece**
Two comb size available to provide the best comfort to the shooter
- 02 Mag position**
- 03 Bullpup System**
- 04 Comfort rear pad**
To provide the best comfort and stability to the shooter

- 05 Two spacers to adapt the LOP**
To the shooter needs, LOP 355 mm max. (med.= 349 mm, min.= 343 mm)
- 06 Improved ergonomics**
The advanced stock design provide multiple grip and shooting position
- 07 Barrel**
490 mm barrel length
- 08 Picatinny rail**
Two later picatinny rails with mags rack
- 09 Straight-pull loading system**
To provide smooth and fast reload

- 10 Decompression chamber and holes**
To minimize the air turbulence at the muzzle
- 11 Trigger group**
Two stage trigger
- 12 Interchangeable pistol grip**
Two different size of pistol grip to provide the best comfort and ergonomics to the shooters
- 13 Integrated compensator**
To minimize the turbulence beyond the pellets and to be more accurate on target

- 14 Picatinny**
With mag rack
- 15 Air tank**
265 cc air volume tank
250 bar max pressure
- 16 Hi-Capacity Magazine**
11 rounds in 4,5 mm; 9 rounds in 5,5 mm;
8 rounds in 6,35 mm
- 17 Ergonomic front handle grip**
To be more comfortable during the shooting



4,5 mm/.177: 285 m/s - 935 fps 5,5 mm/.22: 240 m/s - 780 fps 6,35 mm/.25: 230 m/s - 755 fps

XM1 BULLPUP

The XM1 Bullpup is recognizable from its exclusive and innovative design developed in Italy from the very best expertise on the design. Inspired by the best in class automotive industries, the Stoeger AIRGUNS designers are constantly engaged on the development of new lines. The care on the details on design defines best in class ergonomics stock, offering better comfort and better accuracy. Ergonomic cocking lever position for a faster second target acquisition.



XM1 BULLPUP CARBON



XM1 BULLPUP

INCLUDED WITH THE RIFLE



MULTI GRIP SYSTEM
Ergonomic Front Handle



CHEEKPIECE
Base - Raised



PRO ADAPTIVE LENGTH
Length of pull adjustable with color spacers for optimal comfort



ERGONOMIC BOLT LEVER
With exclusive THRIDION checkering for maximum grip



MULTI GRIP SYSTEM
Pistol grip: Base blue - XL black

XM1 BULLPUP - TECHNICAL FEATURES

Caliber	4,5 mm /.177 - 5,5 mm /.22 - 6,35 mm /.25	Weight (+/- 0,1)	2,8 Kg
Power source	Precharged pneumatic (PCP) with integrated regulator	Velocity cal. 4,5 mm (+/- 2%) 0,69 g pellet	Up to 285 m/s - 935 fps
Cocking system	Straight Pull	Velocity cal. 5,5 mm (+/- 2%) 1,37 g pellet	Up to 240 m/s - 780 fps
Trigger System	Two stage trigger	Velocity cal. 6,35 mm (+/- 2%) 2 g pellet	Up to 230 m/s - 755 fps
Safety	Manual on trigger	Max energy delivered (+/- 2%)	Cal. 4,5 mm / .177: 28J - Cal. 5,5 mm / .22: 40J - Cal. 6,35 mm / .25: 52J
Sight / Scope Rail	No sight - Picatinny rail	Cylinder Pressure	250 BAR / 3630 PSI fill pressure / Integrated pressure gauge
Stock	Human Tech Design Synt. Stock - Ergonomic Features - MGS Technology Ambidextrous Stock Design - 2 interchangeable combs	Cylinder Size	265cc
Finish	Black Synthetic stock - Black anodized receiver and air cylinder	Rotary magazine	11 shots magazine in cal. 4,5 mm /.177 - 9 shots magazine in cal. 5,5 mm /.22 8 shots magazine in cal. 6,35 mm /.25
Total length	700 mm / 27.5"	Included in the box	Charging connector, 2 magazines, 2 side rails, MGS kit, instruction manual, spare O-rings
Barrel	490 mm - Rifled, blued steel barrel with black anodized barrel cover and integrated air decompression chamber Twist rate (mm) 1:480 - Muzzle thread 1/2" UNF	Suggested for	Medium game hunting / Small game hunting / Varmint control / Target shooting



01 Interchangeable cheekpiece
Monte Carlo for scope

02 Interchangeable cheekpiece
Base for open sight

03 Comfort rear pad
To provide the best comfort and stability to the shooter

04 Two spacers to adapt the LOP
To the shooter needs, LOP 355 mm max. (med.= 349 mm, min.= 343 mm)

05 Improved ergonomics
The advanced stock design provide multiple grip and shooting position

06 Hi-Capacity Magazine
9 rounds in 4,5 mm ; 7 rounds in 5,5 mm

07 Interchangeable pistol grip
Blue base

08 Interchangeable pistol grip
Black XL

09 Pro Adaptive Trigger
Most flexible trigger in its category, the first to offer the progressive regulation of the trigger length (-4 mm +8 mm) to provide smooth and fast reload

10 Thridion Pro Adaptive Checkering EBL system
Ergonomic Bolt Lever is the first lever with exclusive Thridion checkering for maximum grip

11 Anti-reflection angle rear sight

12 Air regulator integrated

13 Left side picatinny rail
With integrated rotary magazine rack and locking magnets. The first revolutionary multi-use picatinny rail developed by the Italian Engineers integrating a rack for 3 spare magazines

4,5 mm/.177: 280 m/s - 920 fps 5,5 mm/.22: 220 m/s - 720 fps

XM1

XM1 ensures the best performance in every shooting situation, thanks to the ergo/anatomical studies performed by Italian Engineers (Human Tech Design) and the best weight-stability ratio of the rifle.



INCLUDED WITH THE RIFLE

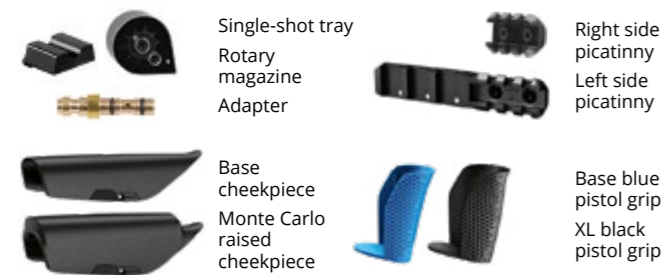

PRO ADAPTIVE LENGTH
Length of pull adjustable with color spacers for optimal comfort



ERGONOMIC BOLT LEVER
With exclusive THRIDION checkering for maximum grip



LEFT SIDE PICATINNY RAIL
Multi-use Picatinny rail integrating a rack for 3 spare magazines



PRO ADAPTIVE TRIGGER
Progressive regulation of the trigger length (-4 mm +8 mm)

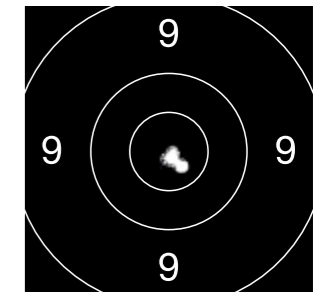

HIGH PRECISION
XM1 PCP rifle can perform the best accuracy in its category with a 5 shot group

XM1 - TECHNICAL FEATURES

Caliber	4,5 mm /.177 - 5,5 mm /.22	Weight (+/- 0,1)	2,5 Kg
Power source	Precharged pneumatic (PCP) with integrated regulator	Velocity cal. 4,5 mm (+/- 2%) 0,69 g pellet	Up to 280 m/s - 920 fps
Cocking system	Bolt Action	Velocity cal. 5,5 mm (+/- 2%) 1,37 g pellet	Up to 220 m/s - 720 fps
Trigger System	Single stage trigger - Adjustable slide trigger (-4mm/+8mm)	Max energy delivered (+/- 2%)	Cal. 4,5 mm / .177: 27J - Cal. 5,5 mm / .22: 34J
Safety	Manual on trigger guard	Cylinder Pressure	200 BAR / 2900 PSI fill pressure / Integrated pressure gauge
Sight / Scope Rail	Adjustable sight - 11 mm dovetail	Cylinder Size	100cc
Stock	Human Tech Design Synt. Stock - Ergonomic Features - MGS Technology Ambidextrous Stock Design - 2 interchangeable combs	Rotary magazine	9 shots magazine in cal. 4,5 mm /.177 - 7 shots magazine in cal. 5,5 mm /.22
Finish	Black Synthetic stock - Black anodized receiver - blued steel air cylinder	Included in the box	Charging connector, 1 magazine, 2 side rails, MGS kit, instruction manual, spare O-rings
Total length	986 mm / 39"	Suggested for	Small game hunting / Varmint control / Target shooting
Barrel	565 mm - Rifled, blued steel barrel with integrated S4 suppressor system Twist rate (mm) 1:480		



reddot winner

**STOEGER AIRGUNS XM1
S4 SUPPRESSOR WON THE RED DOT AWARD
PRODUCT DESIGN**

The "Red Dot" is the award for high design quality. The international jury only awards this sought-after seal of quality to products that feature an outstanding design.

STATEMENT BY THE JURY

The highly dynamic and modern design of the XM1 S4 Suppressor air rifle presents a functionality that was composed with ergonomic requirements in mind.



4,5 mm/.177: 280 m/s - 920 fps 5,5 mm/.22: 220 m/s - 720 fps

XM1 S4 SUPPRESSOR

All innovative XM1 features plus the new generation of integral silencer S4 cumulating baffles and compensators.



XM1 S4 SUPPRESSOR

XM1 S4 SUPPRESSOR - COMBO

INCLUDED WITH THE RIFLE

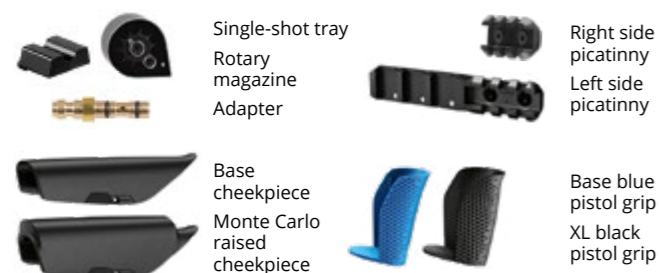

PRO ADAPTIVE LENGTH
Length of pull adjustable with color spacers for optimal comfort



ERGONOMIC BOLT LEVER
With exclusive THRIDION checkering for maximum grip



LEFT SIDE PICATINNY RAIL
Multi-use Picatinny rail integrating a rack for 3 spare magazines



PRO ADAPTIVE TRIGGER
Progressive regulation of the trigger length (-4 mm +8 mm)

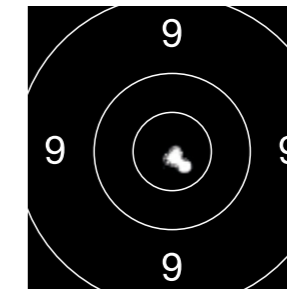

HIGH PRECISION
XM1 PCP rifle can perform the best accuracy in its category with a 5 shot group



PRO SERVICING
Removable silencer cover for easy access to the pressure gauge

XM1 S4 SUPPRESSOR - TECHNICAL FEATURES

Caliber	4,5 mm /.177 - 5,5 mm /.22	Weight (+/- 0,1)	2,6 Kg
Power source	Precharged pneumatic (PCP) with integrated regulator	Velocity cal. 4,5 mm (+/- 2%) 0,69 g pellet	Up to 280 m/s - 920 fps
Cocking system	Bolt Action	Velocity cal. 5,5 mm (+/- 2%) 1,37 g pellet	Up to 220 m/s - 720 fps
Trigger System	Single stage trigger - Adjustable slide trigger (-4mm/+8mm)	Max energy delivered (+/- 2%)	Cal. 4,5 mm / .177: 27J - Cal. 5,5 mm / .22: 34J
Safety	Manual on trigger guard	Cylinder Pressure	200 BAR / 2900 PSI fill pressure / Integrated pressure gauge
Sight / Scope Rail	Adjustable sight - 11 mm dovetail	Cylinder Size	100cc
Stock	Human Tech Design Synt. Stock - Ergonomic Features - MGS Technology Ambidextrous Stock Design - 2 interchangeable combs	Rotary magazine	9 shots magazine in cal. 4,5 mm /.177 - 7 shots magazine in cal. 5,5 mm /.22
Finish	Black Synthetic stock - Black anodized receiver - blued steel air cylinder	Included in the box	Charging connector, 1 magazine, 2 side rails, MGS kit, instruction manual, spare O-rings
Total length	1146 mm / 45"	Suggested for	Small game hunting / Varmint control / Target shooting
Barrel	565 mm - Rifled, blued steel barrel with integrated S4 suppressor system Twist rate (mm) 1:480		

SILENCE REVOLUTION



PATENTED S4 SUPPRESSOR

The new Patented* S4 SUPPRESSOR is the latest Stoeger AIRGUNS design evolution of the integral silencer system, combines the DUAL-EFFECT of the baffles and decompression chamber and now the additional compensator technology.

The new XM1 incorporates the most advanced technology to reduce the noise better than ever.
The best in its class.

*EP3023729 *US10514224 *ZL201580063122.8



red dot winner



4,5 mm/.177: 280 m/s - 920 fps 5,5 mm/.22: 220 m/s - 720 fps

XM1 SPORT

The all-new XM1 SPORT rifles feature important technical solutions, technologies, and two improvements in order to meet the shooters who like to compete in amateur competitions and hit a new niche of market for the brand. The Main features are the new Match Trigger that allows the end user to regulate the trigger, the new Muzzle Brake that allows the rifles to be more accurate reducing the turbulence on the pellets fired, the iconic XM1 Design, and the ergonomics of the rifles, the modularity thanks to the Stoeger AIRGUNS MGS Technology.



INCLUDED WITH THE RIFLE

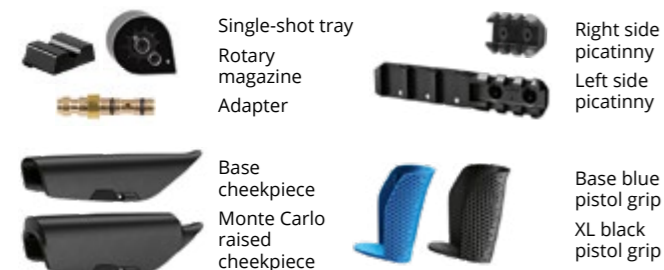

PRO ADAPTIVE LENGTH
Length of pull adjustable with color spacers for optimal comfort



ERGONOMIC BOLT LEVER
With exclusive THRIDION checkering for maximum grip



LEFT SIDE PICATINNY RAIL
Multi-use Picatinny rail integrating a rack for 3 spare magazines



MATCH TRIGGER
Adjustable trigger on 3 axis (X/Y/Z)

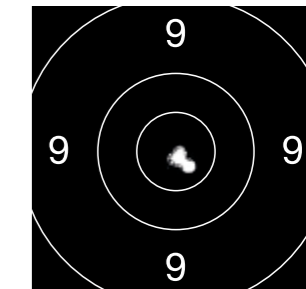

HIGH PRECISION
XM1 PCP rifle can perform the best accuracy in its category with a 5 shot group

XM1 - TECHNICAL FEATURES

Caliber	4,5 mm /.177 - 5,5 mm /.22	Weight (+/- 0,1)	2,5 Kg
Power source	Precharged pneumatic (PCP) with integrated regulator	Velocity cal. 4,5 mm (+/- 2%) 0,69 g pellet	Up to 280 m/s - 920 fps
Cocking system	Bolt Action	Velocity cal. 5,5 mm (+/- 2%) 1,37 g pellet	Up to 220 m/s - 720 fps
Trigger System	Single stage trigger - Adjustable slide trigger (-4mm/+8mm)	Max energy delivered (+/- 2%)	Cal. 4,5 mm /.177: 27J - Cal. 5,5 mm /.22: 34J
Safety	Manual on trigger guard	Cylinder Pressure	200 BAR / 2900 PSI fill pressure / Integrated pressure gauge
Sight / Scope Rail	Adjustable sight - 11 mm dovetail	Cylinder Size	100cc
Stock	Human Tech Design Synt. Stock - Ergonomic Features - MGS Technology Ambidextrous Stock Design - 2 interchangeable combs	Rotary magazine	9 shots magazine in cal. 4,5 mm /.177 - 7 shots magazine in cal. 5,5 mm /.22
Finish	Black Synthetic stock - Black anodized receiver - blued steel air cylinder	Included in the box	Charging connector, 1 magazine, 2 side rails, MGS kit, instruction manual, spare O-rings
Total length	Sport 1019 mm / 40.2" - Sport Suppressor 1090 mm / 42.9"	Suggested for	Small game hunting / Varmint control / Target shooting
Barrel	500 mm -Free floating - Rifled, blued steel barrel - Muzzle brake Twist rate (mm) 1:480		

RX LINE



RX

**THE
RELENTLESS
ADVENTURER**

RX3TAC

Human
Tech Design

STG21105448

 **Stoeger** AIRGUNS

 **BERETTA**
HOLDING



- 01 Comfort rear pad**
To provide the best comfort and stability to the shooter
- 02 Greatest ergonomics stock ever**
- 03 Cheekpiece Setting 3 STEPS:**
Min flush surface
Med + 10mm
Max + 20mm

- 04 The quick adjustable cheekpiece**
Is a unique design specifically made for the RX20TAC by Italian engineers
- 05 Safe**
With comfortable grip
Pro Adaptive Checkering
- 06 Optimized for control and comfort**
For a perfect ergonomics and comfort

- 07 Pro Adaptive length**
Length of pull adjustable with color spacers for optimal comfort
- 08 Improved ergonomics**
The advanced stock design provide multiple grip and shooting position
- 09 Interchangeable pistol grip**
Base black pistol grip checkering level 1
Blue/orange pistol grip rougher embossing finish

- 10 Interchangeable Pads**
Base black Pad checkering level 1
Blue/orange Pads rougher embossing finish
- 11 Picatinny rail**
For bipod
- 12 Tactical precision stock**
And barrel design



RX20TAC



4,5 mm/.177: 305 m/s - 1000 fps 5,5 mm/.22: 240 m/s - 800 fps

RX20TAC

The RX20TAC is Stoeger AIRGUNS first Varmint rifle. It's carefully engineered for best shooting comfort and innovative style that allows exclusive fit and customization: T2 double stage trigger group; 3-9x40 AO scope and high power 2 ring mount; Picatinny side rails for bipod and accessories. Designed for dynamic shooters.



RX20TAC - BARREL
RX20TAC has identical external style to RX20TAC S2 SUPPRESSOR but without internal Suppressor technology. **RX20TAC longer barrel +95 mm extends to the muzzle.**

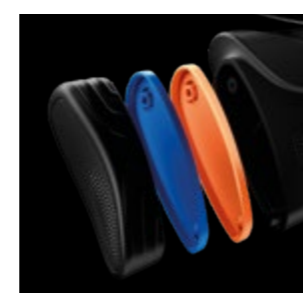

PRO ADAPTIVE LENGTH
Length of pull adjustable with color spacers for optimal comfort



SAFETY BUTTON
With Pro Adaptive Checkering



ADJUSTABLE TRIGGER
Adjustable T2 double stage trigger



MGS CHEEKPIECE
Adjustable cheekpiece in 3 steps, from 0 to 20mm



MULTI GRIP SYSTEM
Black Pro Adaptive Checkering
Blue embossed
Orange embossed



PISTOL GRIP/PADS
Included with the rifle

RX20TAC - TECHNICAL FEATURES

Caliber	4,5 mm /.177 - 5,5 mm /.22	Scope for combo	3-9x40AO scope with two rings
Power source	Spring or Gas Ram and Piston	Total length	44 in. / 1.122 mm
Cocking system	Break-action breech-loader with ergonomic cocking grip	Barrel length	Suppressor 13 in. / 332 mm; NO Suppressor 16.3 in. / 416 mm
Trigger	Stoeger AIRGUNS Adjustable trigger T2 - double stage	Weight	3 Kg without scope
Safety	Automatic, ambidextrous safety mounted on back of receiver	LOP	Max 370 mm - Medium 363 mm - Low 356 mm
Stock	Human Tech Design Stock with Pro Adaptive Checkering and Multi Grip System MGS	Velocity cal. 4,5 mm with alloy pellet	360 m/s - 1200 fps
Finish	Black Synthetic - Rifled, blued steel barrel	Velocity cal. 4,5 mm with lead pellet	305 m/s - 1000 fps
Rail for scope	Integral dovetail scope rail on receiver	Velocity cal. 5,5 mm with lead pellet	240 m/s - 800 fps



4,5 mm/.177: 200 m/s - 660 fps 5,5 mm/.22: 150 m/s - 500 fps

RX5TAC - COMPACT FOR EVERY SHOOTER

Engineered for the whole family, the compact design with the industry leading RXTAC comfort adjustable stock is specifically tailored to the shooter needs and usability scenario. Double stage trigger, adjustable cheekpiece and pull length, extremely performant without compromise on power, comfort, quality, fun.



RX5TAC

RX5TAC - COMBO



PRO ADAPTIVE LENGTH
Length of pull adjustable with color spacers for optimal comfort



SAFETY BUTTON
With Pro Adaptive Checkering



MGS CHEEKPIECE
Adjustable cheekpiece in 3 steps, from 0 to 20mm



MULTI GRIP SYSTEM
Black Pro Adaptive Checkering
Blue embossed
Orange embossed



PISTOL GRIP/PADS
Included with the rifle

RX5TAC - TECHNICAL FEATURES

Caliber	4,5 mm /.177 - 5,5 mm /.22	Rail for scope	Integral dovetail scope rail on receiver
Power source	Spring Piston	Scope for combo	4x32 with two rings
Cocking system	Break-action breech-loader with ergonomic cocking grip	Total length	41 in. / 1.030 mm
Trigger	Double stage - factory set	Barrel length	16.5 in. / 420 mm
Safety	Automatic, ambidextrous safety mounted on back of receiver	Weight	2,4 Kg without scope
Front sight	Hooded front sight with a red, fiber-optic insert	LOP	Max 370 mm - Medium 363 mm - Low 356 mm
Rear sight	Fiber-optic, fully adjustable for elevation and windage	Velocity cal. 4,5 mm with alloy pellet	245 m/s - 810 fps
Stock	Human Tech Design Stock with Pro Adaptive Checkering and Multi Grip System MGS	Velocity cal. 4,5 mm with lead pellet	200 m/s - 660 fps
Finish	Black Synthetic - Rifled, blued steel barrel	Velocity cal. 5,5 mm with lead pellet	150 m/s - 500 fps

4,5 mm/.177: 140 m/s - 450 fps

RX3TAC - FOR YOUNG ADVENTURERS

RX3TAC is the most flexible rifle for kids. Without compromise, best comfort with double stage trigger, automatic safety, adjustable cheekpiece and pull length, adjustable open sights with fiber optic, rail for scope and Picatinny rails for accessories.



RX3TAC

RX3TAC - COMBO



PRO ADAPTIVE LENGTH
Length of pull adjustable with color spacers for optimal comfort



SAFETY BUTTON
With Pro Adaptive Checkering



MGS CHEEKPIECE
Adjustable cheekpiece in 3 steps, from 0 to 20mm



MULTI GRIP SYSTEM
Black Pro Adaptive Checkering
Blue embossed
Orange embossed



PADS
Included with the rifle

RX3TAC - TECHNICAL FEATURES

Caliber	4,5 mm /.177	Rail for scope	Integral dovetail scope rail on receiver
Power source	Spring Piston	Scope for combo	4x32 with two rings
Cocking system	Break-action breech-loader with ergonomic cocking grip	Total length	35.4 in. / 900 mm
Trigger	Double stage - factory set	Barrel length	14.5 in. / 370 mm
Safety	Automatic, ambidextrous safety mounted on back of receiver	Weight	2,1 Kg without scope
Front sight	Hooded front sight with a red, fiber-optic insert	LOP	Max 370 mm - Medium 363 mm - Low 356 mm
Rear sight	Fiber-optic, fully adjustable for elevation and windage	Velocity cal. 4,5 mm with alloy pellet	170 m/s - 560 fps
Stock	Human Tech Design Stock with Pro Adaptive Checkering and Multi Grip System MGS	Velocity cal. 4,5 mm with lead pellet	140 m/s - 450 fps
Finish	Black Synthetic - Rifled, blued steel barrel		

4,5 mm/.177: 305 m/s - 1000 fps 5,5 mm/.22: 240 m/s - 800 fps

RX40 - SINGULAR PERSONALITY

Smart and designed to place leisure and fun at the heart of the precision shooting experience. The RX40 rifle has been designed for those who seek the utmost style and comfort. Great ergonomics of the stock and easy under lever cocking.

PRECISION AND POWER

- Fixed barrel single shot for optimal precision
- Barrel and cylinder a solidly assembled in one strong unit
- Flip-up magazine

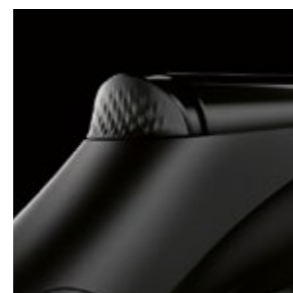

SAFETY BUTTON
With Pro Adaptive Checkering



FLIP-UP MAGAZINE



RECOIL ABSORBING PAD
with Pro Adaptive anti slip checkering



ADJUSTABLE TRIGGER
Adjustable T2 double stage trigger



FIBER OPTIC FRONT SIGHT
Release button Underlever cocking



MULTI GRIP SYSTEM
(only on Synthetic finish rifles) Black Pro Adaptive Checkering pads, Blue embossed pads, Orange embossed pads



**The RX Hardwood finish rifles do not feature the MGS technology and do not include the interchangeable pads*

RX40 - TECHNICAL FEATURES

Caliber	4,5 mm /.177 - 5,5 mm /.22	Rail for scope	Integral dovetail scope rail on receiver
Power source	Spring or Gas Ram and Piston	Scope for combo	3-9x40 AO with high power mount
Cocking system	Under lever cocking - Fixed barrel single shot for optimal precision	Total length	43 in. / 1.090 mm
Trigger	Stoeger AIRGUNS Adjustable trigger T2 - double stage	Barrel length	16.5 in. / 420 mm
Safety	Automatic, ambidextrous safety mounted on back of receiver	Weight	3 Kg without scope
Front sight	Hooded front sight with a red fiber-optic	LOP	Max 370 mm - Medium 363 mm - Low 356 mm
Rear sight	Fiber-optic, fully adjustable for elevation and windage	Velocity cal. 4,5 mm with alloy pellet	360 m/s - 1200 fps
Stock	Human Tech Design Stock with Pro Adaptive Checkering and Multi Grip System MGS	Velocity cal. 4,5 mm with lead pellet	305 m/s - 1000 fps
Finish	Black Synthetic Green Synthetic Grey Synthetic Hardwood - Rifled, blued steel barrel	Velocity cal.5,5 mm with lead pellet	240 m/s - 800 fps

THE EVOLUTION OF SILENCE

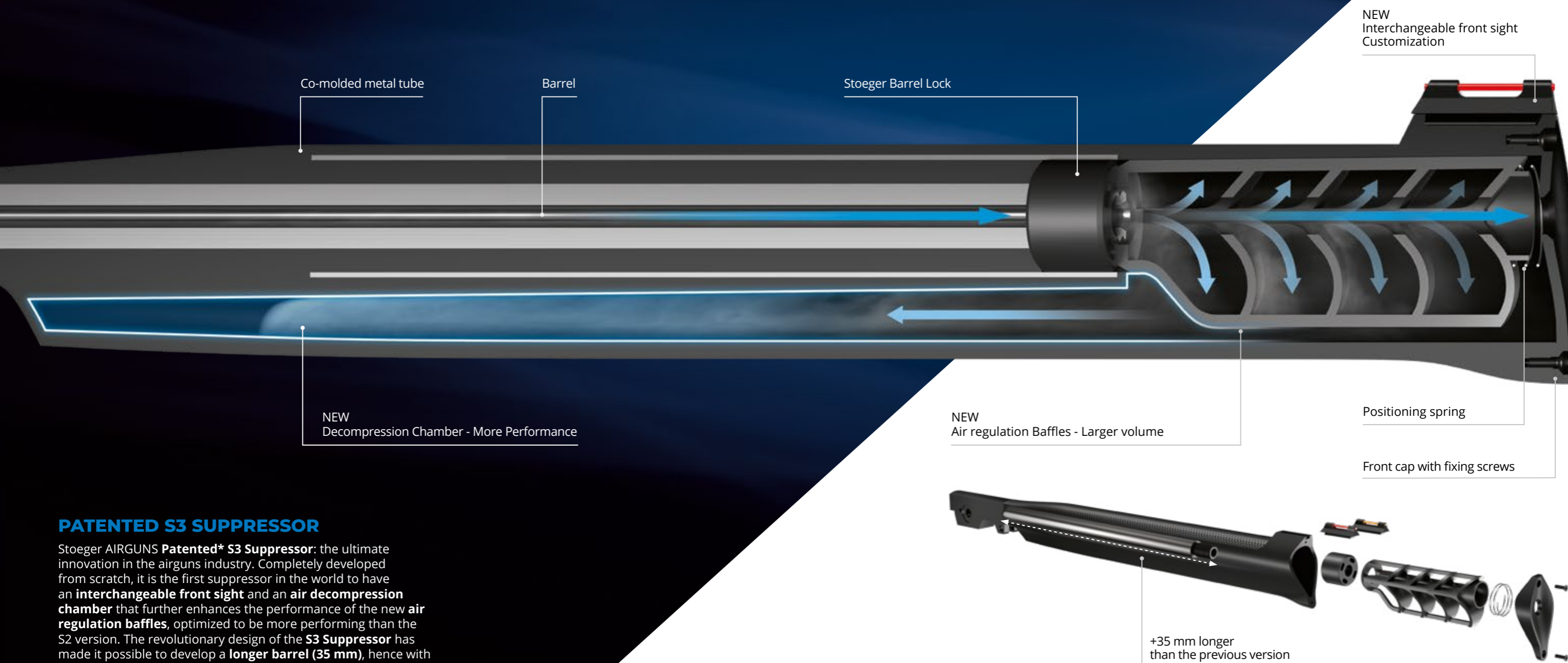

PATENTED S3 SUPPRESSOR

Stoeger AIRGUNS **Patented* S3 Suppressor**: the ultimate innovation in the airguns industry. Completely developed from scratch, it is the first suppressor in the world to have an **interchangeable front sight** and an **air decompression chamber** that further enhances the performance of the new **air regulation baffles**, optimized to be more performing than the S2 version. The revolutionary design of the **S3 Suppressor** has made it possible to develop a **longer barrel (35 mm)**, hence with a greater precision of shooting.

Innovation, Technology and Style are the three principles behind our "Human Tech Design" philosophy. The Stoeger AIRGUNS RX20 S3 incorporates the very best in style and performance. The S3 Suppressor System combines the functions of an internal air regulation baffles and the new decompression chamber, that work in tandem to reduce noise better than any other airguns on the market.

*EP3023729 *US10514224 *ZL201580063122.8

S3
SUPPRESSOR

 **Stoeger** AIRGUNS

 **BERETTA**
HOLDING

4,5 mm/.177: 305 m/s - 1000 fps 5,5 mm/.22: 240 m/s - 800 fps

RX20 - PERFECT FEELING

Innovation, Technology and Style are the three principles behind a fully new concept. Stoeger AIRGUNS designer's challenge has been to develop and implement something special that could convey new emotions. The unique design and ergonomic shapes makes the air rifle fit perfectly to the shooter.



RX20 SPORT - BARREL
RX20 SPORT has identical external style to RX20 S3 SUPPRESSOR but without internal Suppressor technology. **RX20 SPORT longer barrel +95 mm extends to the muzzle.**



RECOIL ABSORBING PAD
with Pro Adaptive anti slip checkering



SAFETY BUTTON
With Pro Adaptive Checkering



ADJUSTABLE TRIGGER
Adjustable T2 double stage trigger



INTERCHANGEABLE FRONT SIGHT
(S3 Suppressor - Sport) with red and orange fiber optic



MULTI GRIP SYSTEM
(only on Synthetic finish rifles) Black Pro Adaptive Checkering pads, Blue embossed pads, Orange embossed pads



**The RX Hardwood finish rifles do not feature the MGS technology and do not include the interchangeable pads*

RX20 S3 SUPPRESSOR / RX20 SPORT / RX20 DYNAMIC - TECHNICAL FEATURES

Caliber	4,5 mm /.177 - 5,5 mm /.22	Rail for scope	Integral dovetail scope rail on receiver
Power source	Spring or Gas Ram and Piston	Scope for combo	4x32 with two rings
Cocking system	Break-action breech-loader with ergonomic cocking grip	Total length	S3 Suppressor / Sport: 44 in. / 1.122 mm - Dynamic: 42.5 in. / 1.080 mm
Trigger	Stoeger AIRGUNS Adjustable trigger T2 - double stage	Barrel length	S3 Suppressor: 14 in./366,7 mm - Sport: 18 in./461,8 mm - Dynamic: 16.5 in./419,7 mm
Safety	Automatic, ambidextrous safety mounted on back of receiver	Weight	3 Kg without scope
Front sight	Interchangeable front sight (S3 Suppressor, Sport) Hooded front sight with a red and orange, fiber-optic	Velocity cal. 4,5 mm with alloy pellet	360 m/s - 1200 fps
Rear sight	Fiber-optic, fully adjustable for elevation and windage	Velocity cal. 4,5 mm with lead pellet	305 m/s - 1000 fps
Stock	Human Tech Design Stock with Pro Adaptive Checkering and Multi Grip System MGS	Velocity cal.5,5 mm with lead pellet	240 m/s - 800 fps
Finish	Black Synthetic Green Synthetic Grey Synthetic Hardwood - Rifled, blued steel barrel		

4,5 mm/.177: 200 m/s - 660 fps 5,5 mm/.22: 150 m/s - 500 fps

RX5 - COMPACT PERFORMANCE

Human Tech Design philosophy translated to a compact and light, easy to handle air rifle with RX aesthetics and functional innovations – to approach the world of air rifles and fun outdoor shooting.



RECOIL ABSORBING PAD
with Pro Adaptive
anti slip checkering



SAFETY BUTTON
With Pro Adaptive Checkering



ADJUSTABLE TRIGGER
Adjustable T2
double stage trigger

RX5 - TECHNICAL FEATURES

Caliber	4,5 mm /.177 - 5,5 mm /.22	Rail for scope	Integral dovetail scope rail on receiver
Power source	Spring piston	Scope for combo	4x32 with two rings
Cocking system	Break-action breech-loader with ergonomic cocking grip	Total length	41 in. / 1.030 mm
Trigger	Double stage - factory set	Barrel length	16.5 in./420 mm
Safety	Automatic, ambidextrous safety mounted on back of receiver	Weight	2,4 Kg without scope
Front sight	Hooded front sight with a red, fiber-optic insert	Velocity cal. 4,5 mm with alloy pellet	245 m/s - 810 fps
Rear sight	Fiber-optic, fully adjustable for elevation and windage	Velocity cal. 4,5 mm with lead pellet	200 m/s - 660 fps
Stock	Human Tech Design Stock with Pro Adaptive Checkering	Velocity cal.5,5 mm with lead pellet	150 m/s - 500 fps
Finish	Black Synthetic Green Synthetic Grey Synthetic Hardwood - Rifled, blued steel barrel		

PELLETS

ACCURACY TO MEET EVERY REQUIREMENT FOR AIR RIFLES

Every shooter has specific requirements for his airgun when it comes to the ammunition. Our finely classified programme with a wide range of pellet shapes and weights will satisfy every need. Accuracy is a combination of several variables, the quality of the pellets is most important. Stoeger AIRGUNS pellets are Made in Germany with high tech technology.

PRACTICE TARGET

Lightweight accurate pellet for training and hobby shooting. Meets all underlying requirements. For universal use, at an extremely favourable price.
Cal. 4,5mm / .177 and 5,5mm / .22



GREAT PENETRATION

Medium-weight, very accurate pellet for hunting and precision shooting at medium ranges. Aerodynamic design for flat trajectories and perfect penetration.
Cal. 4,5mm / .177 and 5,5mm / .22



MAX SHOCK

Heavy, accurate hunting pellet for medium ranges. High impact and penetration with maximum shock effect, with blood grooves.
Cal. 4,5mm / .177 and 5,5mm / .22



SUPER ACCURATE

Extremely accurate competition and training pellet for performance-oriented shooters. Tight shot groups, clean-cut bullet holes, excellent value for money.
Cal. 4,5mm / .177 and 5,5mm / .22



MAX PENETRATION

Heavy, exceptionally accurate pellet for long ranges. No lead-fouling, improved drive in barrel, no contact with lead thanks to special copper coating (20% harder than comparable lead pellets). First-class aerodynamic design for high impact and penetration. Low deformation of pellet. Tight shot groups.
Cal. 4,5mm / .177 and 5,5mm / .22



HIGH SHOCK, MAX IMPACT

Heavy, exceptionally accurate hunting pellet for long ranges. Advanced X-HOLLOW design with deep hollow point and best aerodynamic properties for maximum impact, high penetration and controlled deformation of pellet. Tight shot groups.
Cal. 4,5mm / .177 and 5,5mm / .22



6-PACK 4.5MM / .177 DIFFERENT PELLETS

Test all our premium pellets in your airgun and choose the most appropriate for you:

- Velocity
- Shock effect
- Penetration

X-MATCH (40 Pellets) - X-POWER (35 Pellets)
X-MAGNUM (30 Pellets) - X-HOLLOW (30 Pellets)
X-HUNT (40 Pellets) - X-SPORT (40 Pellets)



Stoeger AIRGUNS reserves the right to make modifications to the products shown in this catalogue at any time without prior notice. The finishings shown in this catalogue are approximate, as a printed reproduction causes inevitable colour differences.

- Art Direction
- Graphic design
- Photo shooting
- 3D visualization
- Digital post production

Studiopieri Web & Graphic Agency



